

PRODUCT INFORMATION

Product Specification:

- Holding force (approx) - Z8 series : 550kg - 580kg
Z4 series : 250kg - 280kg
Z2 series : 120kg - 140kg
- Voltage: 12V / 24VDC (Selectable)
Note: Factory default setting is 12VDC.
- **Current draw:**
Z8 series : 410mA at 12VDC; 220mA at 24VDC
Z4 series : 460mA at 12VDC; 230mA at 24VDC
Z2 series : 300mA at 12VDC; 150mA at 24VDC

Z8 and Z4 series with Hall/Bond Sensor:

- The LED operation colour can be field set. The colours can be reversed simply by reversing the 2 pin plug connection on the PCB.
- For Z2 series, there is no LED for Bond Sensor model.
- The factory default setting is as follow:
LED indicator off (No power to the magnet)
LED indicator red (Power on magnet, door open)
LED indicator green (Power on magnet, door closed)
- **Note: Where the EML has both Hall/Bond Sensor and Door Position Sensor (Reed Switch), the LED indicates as Bond Sensor Model.**

Product Dimensions (mm):

Z8 series - (L)266 x (H)72 x (D)40
Z4 series - (L)238 x (H)48 x (D)27
Z2 series - (L)170 x (H)42 x (D)23

WIRING INSTRUCTION

Installation Requirements:

- Unscrew and remove cover plate on EML to change voltage.
 - Adjust PCB shunt settings for correct operating voltage prior to applying power.
For a 12 volt system
- For a 24 volt system only one shunt is required, joining pins 2 & 3.

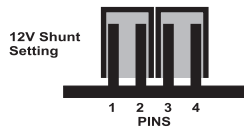

Product Power Input Wiring:

For Z8 and Z4 series, this can be wired directly onto the PCB terminal block that has label + and -.
For Z2 series, it is with flying leads. Red wire is + and black wire is -.
(NO NEED TO REMOVE COVER PLATE FOR Z2)

Wiring for models with Hall/Bond Sensor:

For Z8 and Z4 series, the signal is given out from Single Pole Double Throw (SPDT) relay. Wiring can be done through PCB 3-block terminal labeled NC, COM and NO. For Z2 series, there are 3 flying leads for this model. Black wire is COM, green wire is NO and white wire is NC.

Wiring for models with Door Position Sensor:

For Z8 series, the signal is given out from the 3 block terminal (NC, COM, NO) that is labelled Reed on the PCB. For Z4 series, there are 3 flying leads. Black is COM, green is NO and white is NC.

MOUNTING INSTRUCTION

Step 1.

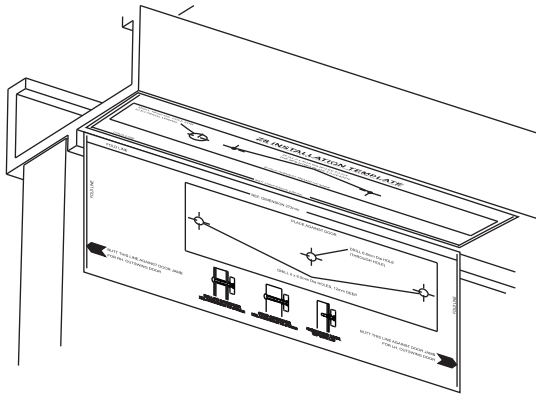

- Use the supplied template to determine the correct location and size of mounting holes for both the door and frame header. Ensure that the door opens away from the EML. In the case of a single door, the EML is positioned as close as possible to the vertical section of the door jamb.

Step 2.

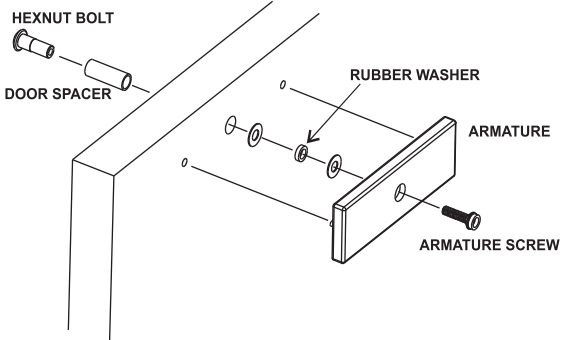

- Align the armature plate on the door using sight or the template supplied.
- Mark and drill holes then mount the armature to the door. Make sure that the armature plate is not over tightened and that it is installed as shown in the following diagram. The armature plate must be free to self align with the door.

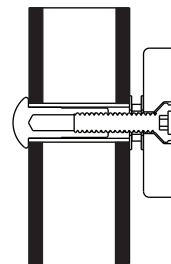

**HOLLOW CORE
DOOR ENLARGE
HOLE TO Ø16mm**

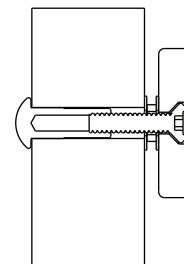

**SOLID CORE
DOOR ENLARGE
HOLE TO Ø12mm**

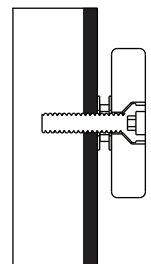

**REINFORCED
DOOR
TAP M6X1.0 for Z2
TAP M8X1.25 for Z4, Z8**

MOUNTING ARMATURE ON DIFFERENT DOOR TYPES

Step 3.

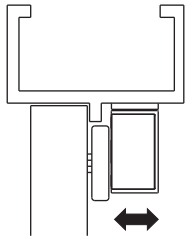

ADJUST POSITION OF
MAGNET RELATIVE TO
THE ARMATURE

- Loosely install the mounting plate using two of the supplied philips head mounting screws in the elongated slots. Attach the EML to the mounting plate.
- Ensure the armature and magnet are aligned. Adjust the mounting plate to suit and then drill the appropriate sized holes in the door header for the remaining attachment screws.

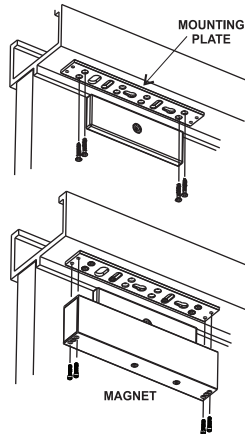

The following diagrams indicates possible installation methods. Determine whether optional "L" or "Z" brackets are required to complete the installation. Suits door thickness 32 to 45mm, (Z8 Model shown)

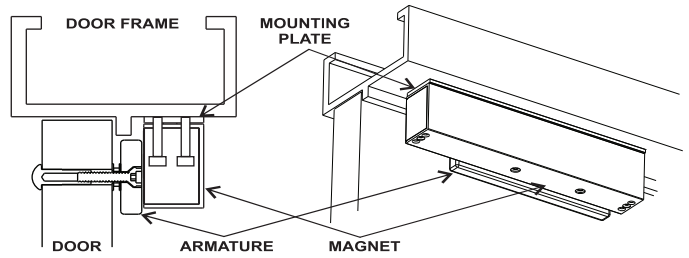

Out swinging door using the standard mounting plate.

MOUNTING WITH L & Z BRACKETS

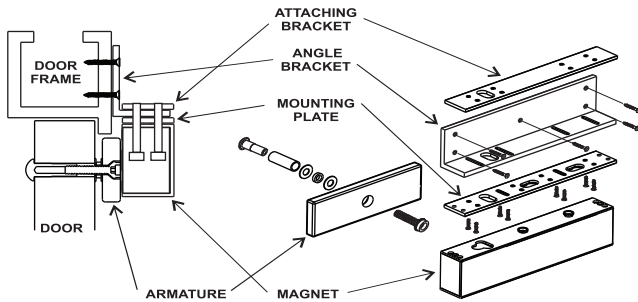

Out swinging door using an "Angle" bracket to extend the header depth.

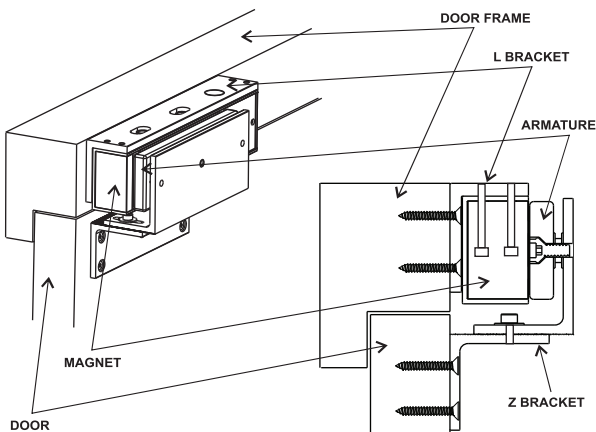

Assemble brackets as shown.

MOUNTING ON GLASS DOORS

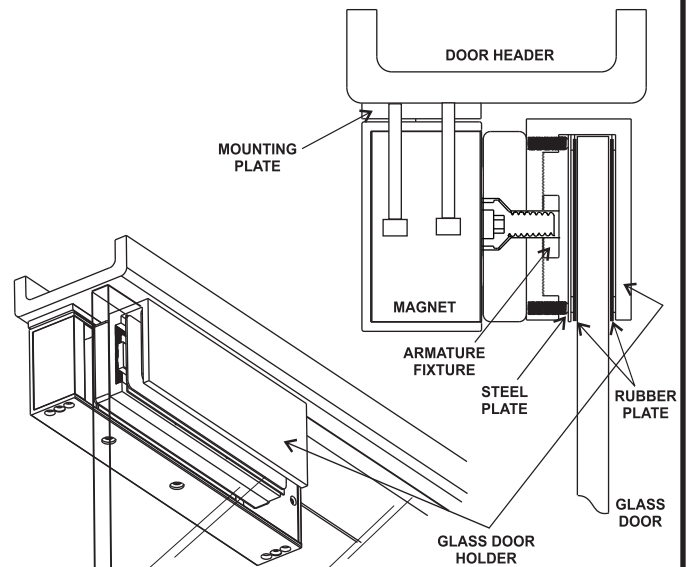

Assemble Glass Door brackets as shown.

ELECTRICAL CONNECTION

- Connect electrical wiring according to the local appropriate wiring rules. Make sure the correct voltage on the PCB has been selected prior to turning on the power. Failure to do this could damage the unit. Factory default voltage is set to 12volts DC.
- Note:** If a door closer has been fitted then adjust it so that the armature closes lightly against the magnet. This will avoid damage to the magnet and will also make the door operation quieter.

MAINTENANCE

- The electro magnetic lock does not require much ongoing maintenance. The customer should be advised to keep the mating faces of the armature and magnet clean making sure that no abrasive materials are used to clean the faces.
- Do not spray the magnet or armature with any chemicals such as lacquer as the release of the electro magnet may be compromised.**